

eLite User Manual



Model: eLite

2023.12 Version 1.1

Copyright © ePropulsion Technology Limited

Acknowledgement

Thank you for purchasing a product from ePropulsion, world leaders in clean, safe and reliable electric marine propulsion systems. We are sure you'll be pleased with your new motor and welcome your feedback at www.epropulsion.com.

Using This Manual

Before operating this product, it is essential to carefully read and understand this user guide. It provides detailed instructions on the correct and safe usage of the product. By using this product, you acknowledge that you have thoroughly read, understood, and agreed to all the information in this manual. It is crucial not to operate the electric outboard motor until you have a complete understanding of its operation. Furthermore, refrain from lending the outboard motor to individuals who are unfamiliar with its operation. Please be aware that ePropulsion cannot be held responsible for any financial losses or personal injuries resulting from non-compliance with the instructions provided in this manual.

Kindly note that ePropulsion maintains a policy of continuous product optimization and reserves the right to update the content of this manual at any time. For the latest version, please visit our website at www.epropulsion.com. If you encounter any discrepancies between your product and this manual or have any inquiries regarding the product or this manual, please visit our website or contact our customer support. ePropulsion retains the right to make the final interpretation of this manual.

This manual is available in multiple languages. In the event of any inconsistencies between different language versions, the English version shall prevail.

Furthermore, ePropulsion retains all relevant intellectual property and industrial rights, including copyrights, patents, trademarks, and designs.

Safety Warning Instructions

At ePropulsion, we prioritize safety and strive to minimize risks to individuals and property. We strongly advise all individuals who come into contact with our products to exercise caution, utilize common sense, adhere to the instructions provided in this manual, and give special attention to the safety information outlined in both the manual and on the product labels. This includes individuals involved in the installation, operation, maintenance, and servicing of the product.

Within the user manual and/or on labels affixed to the product, you will find the following information symbols:

Danger or Warning Signs:

These signs indicate potential hazards or significant risks that, if not avoided, could lead to

severe personal injury or even death. It is crucial to exercise extra caution and attentiveness to ensure your safety and the safety of the product.



Tips or Important Points:

These sections provide valuable information and insights that facilitate a quick understanding of the outboard motor's usage and enhance operational efficiency. We strongly urge you to read and follow the instructions that follow the safety warning signs.



Important Warning:

When it comes to the installation, operation, maintenance, or servicing of ePropulsion products, various safety risks are involved. It is essential to remain vigilant, execute the necessary operations prudently, and prioritize safety throughout the process.

Identification and Record of Serial Number

The serial number of your product can be found in the location shown below. The serial number may be required when purchasing accessories, seeking service or warranty support, or in the unfortunate event of motor theft.

Please ensure that you keep a note of the serial number in a readily accessible and safe location for future reference.

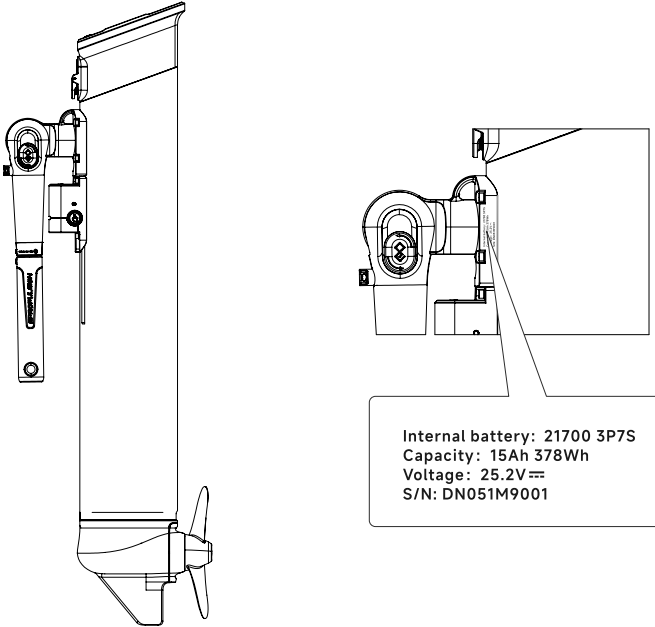

Table of Contents

Acknowledgement	1
Using This Manual	1
Safety Precautions and Guidelines	1
Identification and Record of Serial Number	3
1 Product Overview	6
1.1 In the Package.....	6
1.2 Parts and Diagram	8
1.3 Specification.....	9
1.4 Important Notes Before You Start	10
1.4.1 Motor Selection.....	10
1.4.2 Users	10
1.4.3 General Boating Advice.....	10
1.4.4 Specific to this Motor:	11
1.5 Declaration of Conformity	11
1.6 Operation is subject to the following two conditions	12
1.7 Product Disposal.....	13
2 Tiller	14
2.1 Tiller Angle.....	14
2.1.1 Free Mode.....	14
2.1.2 Fixed Mode.....	14
2.2 Throttle Rotation	15
2.3 Tiller Extension.....	15
2.4 Steering Angle.....	16
3 Clamp Bracket & Quick Release Mount	17
3.1 Shaft Length.....	17
3.2 Trim Angle	17
3.3 Shallow Water Mode.....	19
3.4 Anti-grounding Mode	20
3.5 Steering Friction Adjustment/Lock.....	22
4 Installation	23
4.1 Clamp Bracket Installation	23
4.2 Motor Installation.....	24
4.3 Motor Removal.....	25

5 Operation.....	27
5.1 Checklist before start	27
5.2 Starting	27
5.2.1 Standard Mode	27
5.2.2 Sport Mode	29
5.3 Stopping.....	29
5.4 Tilt Up and Release	30
5.4.1 Motor Tilt.....	31
5.4.2 Motor Release.....	31
6 Interface.....	33
6.1 Display Panel	33
6.2 Power Button.....	33
6.3 Kill Switch	35
6.4 Battery Indicator.....	37
6.5 Troubleshooting	38
6.5.1 Fault Indicator.....	39
6.5.2 Error Codes	39
7 Battery	40
7.1 AC-DC Charging	40
7.2 Charging Indicator.....	41
8 USB Type-C Output.....	42
9 Maintenance.....	43
9.1 Precautions	43
9.2 Propeller Inspection/Replacement	43
9.3 Maintenance of Electrical Contacts.....	44
10 Transportation and Storage	45
10.1 Portable	45
10.2 Outboard Bag	46
11 Emergency Situations/Actions	47
11.1 Collision.....	47
11.2 Outboard Submerged/Swamped	47
12 Warranty.....	48
12.1 Terms of Warranty	48
12.2 Scope of Warranty	49
12.3 Limited Warranty Claim Procedures.....	49

1 Product Overview





ePropulsion eLite electric outboard motor is a lithium battery-powered outboard motor. With a power output of up to 750W, it provides reliable propulsion for numerous small boat applications. The eLite has several design features that facilitate transport and storage, and offer greater user convenience, including:

- integrated information display
- foldable, extendable tiller to suit different boats and driving positions
- quick-release clamp bracket for faster installation/removal
- adjustable shaft length for use on different boats
- USB Type-C charging socket for external electronics

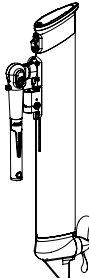
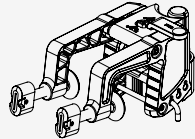
1.1 In the Package

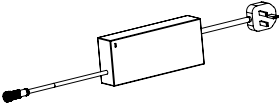
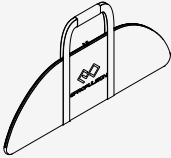
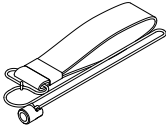
When opening the package, please check the contents against the list below. If any items are missing or damaged, please contacting your dealer for assistance.

No.	Items	Qty.	Figure	Function
1	Outboard Main Part	1		Provide the main propulsion of the boat
2	Clamp Bracket	1		Connects the outboard motor to the transom securely, with quick-release function

No.	Items	Qty.	Figure	Function
3	AC Charger	1		Charge the battery
4	Outboard Bag	1		For storage and transportation of the outboard motor
5	Kill Switch and Wristband	2		To stop the outboard motor in an emergency
6	Hex Wrench	1		To adjust the screws of the quick-release bracket clamp and replace the propeller
7	User Manual, Warranty Card	1		/
8	Quick Start Guide	1		Quick reference guide to the outboard's main functions



We recommend you keep the original packaging for transport and storage.

1.2 Parts and Diagram

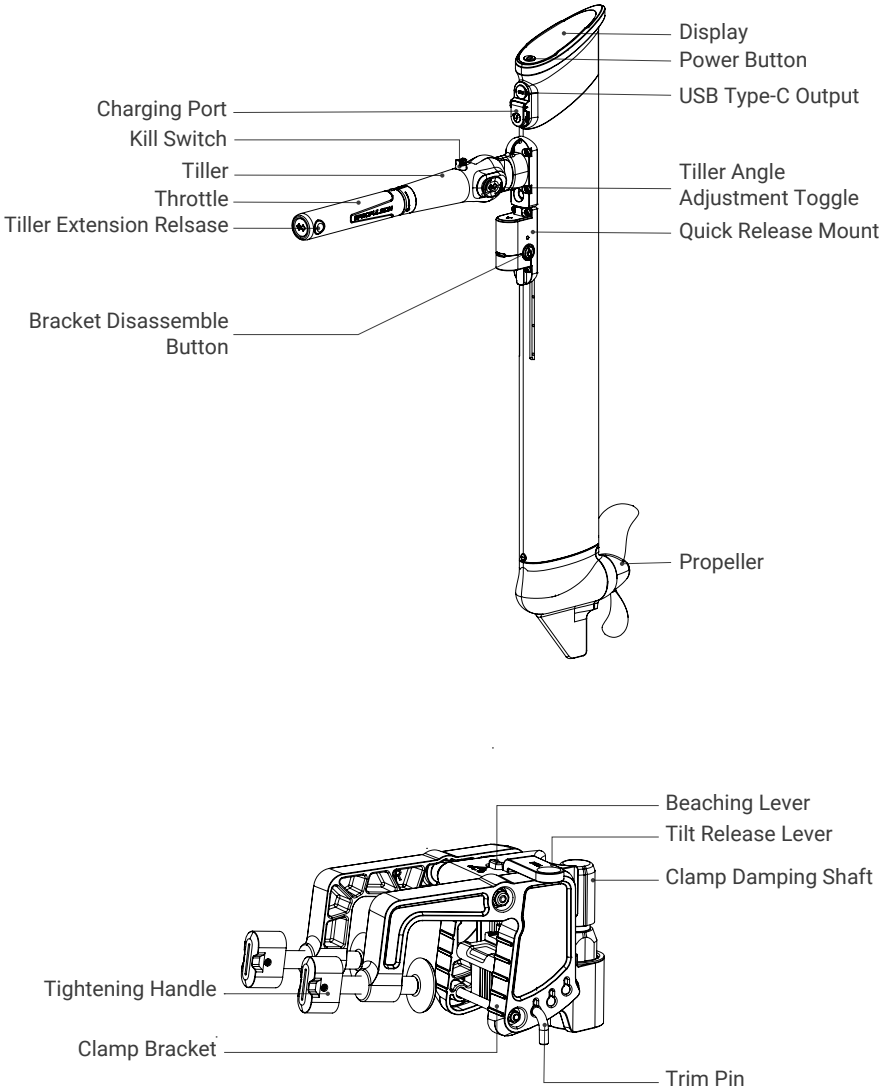

Figure 1.1

1.3 Specification

Model	eLite
Rated Input Power	500 W
Peak Input Power	750 W
Rated input voltage	25.2 Vdc
Input voltage range	19.25 Vdc - 29.4 Vdc
Weight	6.7 kg (without clamp bracket)
Adjustable Shaft Length Range (from top of propeller to transom)	282.5 - 401 mm
Dimensions (Length * Width * Height, without bracket clamp)	297 mm * 75 mm * 890 mm (without bracket clamp)
Cooling Method	Natural water cooling
Rated Power Rotational Speed Range	1450 - 1800 rpm
Operating Temperature	-5 - 55 °C
Storage Temperature	-20 - 45 °C
Operation and Interaction	Tiller with rotary throttle Kill Switch Display Power Button
Propeller	Two-blade propeller, diameter: 194mm
Tilt Angle	75°
Steering Angle	±70°
Battery Capacity	378 Wh
Battery Type	Built-in non-removable battery
Waterproof Rating	IP67

1.4 Important Notes Before You Start

1.4.1 Motor Selection

Please follow the boat manufacturer's specifications and the advice of an ePropulsion authorised dealer in choosing a suitable outboard motor. Do not exceed the maximum power permitted, and do not overload the motor.

1.4.2 Users

- (1) This product must only be operated by adults who have fully read and understood this manual. ePropulsion accepts no liability for any damage or malfunction caused by operations that contradict the content of this manual.
- (2) You should only use this motor system if you are also familiar with all other aspects of operating your boat. If the boat is new to you, you should learn how the boat behaves in different conditions, including tide, wind and waves. Take professional advice and instruction as necessary.

If you are in any doubt about the operation of the motor or boat please consult your dealer before use.

1.4.3 General Boating Advice

Before operation:

- (1) Familiarize yourself with all the functions and operations of the motor and the boat it's fitted to. Make sure at least one other person on board is sufficiently familiar with the boat and its systems that they could take over from you in the event of emergency
- (2) Check the weather conditions and refer to weather forecasts before boating. Avoid boating in hazardous weather conditions.
- (3) Check there is sufficient and operational safety equipment, including but not limited to: life jackets, buoyancy aids or other personal flotation devices, fire extinguishers, bells and whistles, communication equipment, and paddles, etc.
- (4) Check that the boat and equipment comply with local boating safety regulations.
- (5) If the electric outboard motor is the only power source for your boat, make sure the batteries on board have sufficient charge for your round trip. As a minimum you need to calculate distance and battery consumption over that distance, making allowance for the effects of wind, tide and other variables that may affect range.
- (6) Always report your voyage plan to family, friends and authorities where relevant.
- (7) Do not operate the boat under the influence of alcohol or drugs. About 50% of boating accidents are related to alcohol consumption.

During Operation:

- (1) All members of the crew should be equipped with, and wear, a PFD (personal flotation device, eg life jacket, buoyancy aid). Please always wear a PFD when boating.
- (2) Driver should always wear the kill cord (kill switch), by attachment of the lanyard to a secure position on their wrist, ankle, or item of clothing (buoyancy aid, jacket etc). If the driver falls overboard (or accidentally leaves the helm), the lanyard will pull the kill cord off the throttle and stop the outboard.
- (3) Watch carefully for other vessels, swimmers and other objects in the water. Proceed with particular caution when near to harbour, shore or beach and avoid swimming areas if possible.
- (4) If someone falls overboard, or there's a collision, stop the outboard motor immediately (fastest method is to pull kill switch off throttle).

1.4.4 Specific to this Motor:

- (1) If the outboard motor has a significant impact with an object in the water, stop operation immediately. Check outboard for damage and if you think it's safe to operate return to the nearest port at slow speed. If you don't think it's safe to operate call for assistance and a tow. In either case please get an authorised ePropulsion dealer to inspect your motor before use on future occasions.
- (2) Only operate the outboard motor when the propeller is submerged in the water; operating it in air is strictly prohibited.
- (3) If the boat is powered by other means, such as sails, do not leave the outboard motor in the water.
- (4) Rinse the outboard with fresh water each time it's been used in salt water.
- (5) Always keep the charging and Type-c ports cover closing tightly. Clean the charger contacts and USB socket with contact spray about every two months.
- (6) Tilt the outboard motor up out of the water when not in use.
- (7) If the outboard malfunctions, the display will show an error message and may either stop or enter a reduced power mode. The most likely reason for malfunctions include: collision, obstruction (eg seaweed or rope around the propeller), motor temperature too high, low battery voltage.

1.5 Declaration of Conformity

Object:

Product: Electric Outboard Motor

Model: eLite



Company Name: Guangdong ePropulsion Technology Limited

Company Address: Room 801, Building 1, 11 Daxue Road, Songshan Lake, Dongguan, Guangdong Province, China

We declare that the design of the eLite outboard motor complies with the following directives:

EMC Directive 2014/30/EU;

MD Directive 2006/42/EC;

RoHS Directive 2011/65/EU & 2015/863/EU.

Applicable standards:

EN IEC 61000-6-2:2019

EN IEC 61000-6-3:2021

EN 60204-1:2018

EN ISO 12100:2010

IEC 62321-5:2013

IEC 62321-4:2013+AID1:2017

IEC 62321-7-1:2015

IEC 62321-7-2:2017

IEC 62321-6:2015

IEC 62321-8:2017

European Representative Information:

Name: REP Europe GmbH

Address: Werner-von-Siemens-Str. 2, 64319 Pfungstadt, Germany

Phone: +49 157 51253212

Email: info@rep-europe.de

Signed by:



Mr. Tao Shizheng is the CEO and co-founder of Guangdong ePropulsion Technology Limited.

1.6 Operation is subject to the following two conditions:

- (1) This device may not cause harmful interference.
- (2) This device must accept any interference received, including interference that may cause undesired operation.

Note:

This equipment has been tested and found to comply with the limits for a Class B digital device, pursuant to Part 15 of the FCC Rules. These limits are designed to provide reasonable protection against harmful interference in a residential installation. This equipment generates,

uses, and can radiate radio frequency energy and, if not installed and used in accordance with the instructions, may cause harmful interference to radio communications. However, there is no guarantee that interference will not occur in a particular installation. If this equipment does cause harmful interference to radio or television reception, which can be determined by turning the equipment off and on, the user is encouraged to try to correct the interference by one or more of the following measures:

- Reorient or relocate the receiving antenna.
- Increase the separation between the equipment and receiver.
- Connect the equipment into an outlet on a circuit different from that to which the receiver is connected.
- Consult the dealer or an experienced radio/TV technician for help.

1.7 Product Disposal



This marking indicates that this product should not be disposed of with other household waste throughout the EU. To prevent possible harm to the environment or human health from uncontrolled waste disposal, recycle it responsibly to promote the sustainable reuse of material resources. To return your used device, please use the return and collection systems or contact the retailer where the product was purchased. They can take this product for environmentally safe recycling.

2 Tiller

2.1 Tiller Angle

The angle of the tiller can be adjusted anywhere from 90° above to 90° below the horizontal, to suit your position in the boat. In “free mode” it is infinitely variable, whilst in “fixed mode” it has four lockable trim angles: -90°, 0°, 45°, and 90°.

2.1.1 Free Mode

Rotate the tiller adjustment toggle 90° in either direction. The toggle will spring outwards as it's rotated and the tiller can then be adjusted freely to any angle from -90° to 90°.

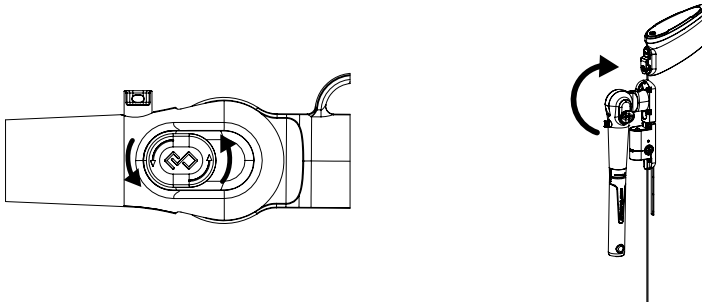

Figure 2.1

2.1.2 Fixed Mode

Pull out the toggle, and the tiller can be adjusted to any of four fixed positions: -90°, 0°, 45°, and 90°. Push toggle back in to lock it.

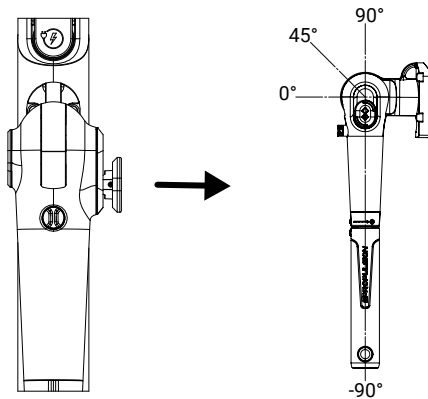

Figure 2.2

2.2 Throttle Rotation

The direction of the motor – forwards or reverse – and the power input are controlled by rotation of the throttle handle (at end of tiller). The F position is for forward, the N position is for neutral, and the R position is for reverse.

Neutral is selected when the raised indicators on the tiller shaft and throttle handle are aligned.

The motor remains in Neutral a few degrees either side of that position when switching between F and R.

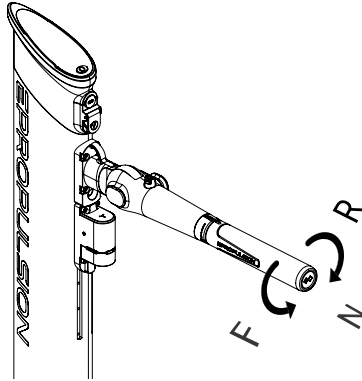

Figure 2.3

2.3 Tiller Extension

The tiller can be extended by up to 13cm, for more convenient positioning in the boat. To do this, press the button at the end of the tiller and pull it outwards. The tiller will automatically lock back in place when it is fully retracted.

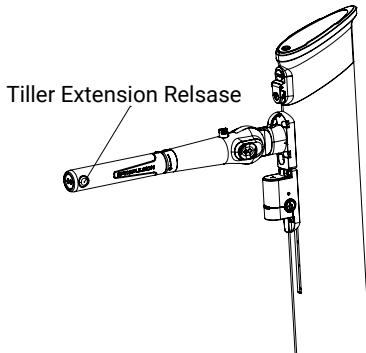

Figure 2.4

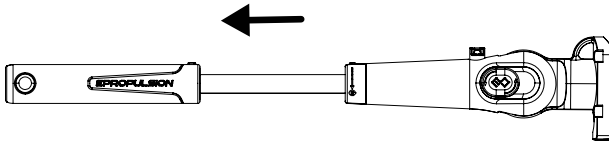

Figure 2.5

 During operation, never tilt the outboard motor while the tiller is extended.

2.4 Steering Angle

The boat is steered by movement of the tiller, which can rotate the motor shaft up to 70° either side of central. The steering friction can be varied, or locked in position, by adjustment to the clamp bracket damping shaft (see section 3.5).

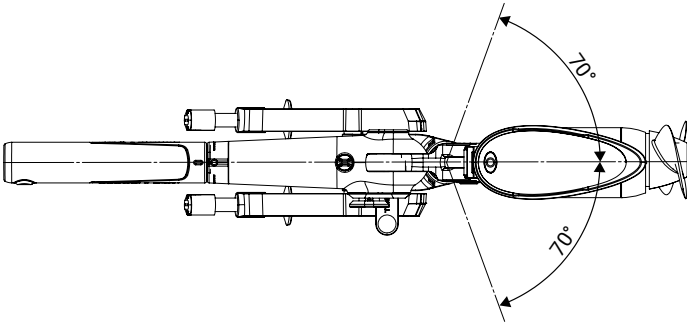

Figure 2.6

3 Clamp Bracket & Quick Release Mount

3.1 Shaft Length

Shaft length is defined as the distance from the top of the propeller to the top of the transom. The shaft length can be adjusted to one of four positions: 401mm, 362.5mm, 322mm, and 282.5mm. The default setting is 401mm. If you need to adjust the shaft length, use the hex wrench to remove the four screws that secure the quick-release mount to the shaft. Adjust the position of the quick-release mount to the shaft length needed. Apply threadlocker on the screws, then put the four screws back in and do up with the hex wrench.

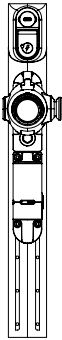

Figure 3.1

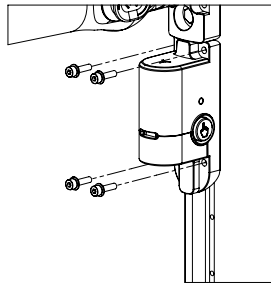

Figure 3.2

3.2 Trim Angle

The outboard's trim can be adjusted to suit different boats and transom angles. Movement of the trim pin in the bracket allows for three positions: 8°, 17°, and 26°. The best position to select is the one where the propeller will be closest to vertical when the boat is loaded and in use.

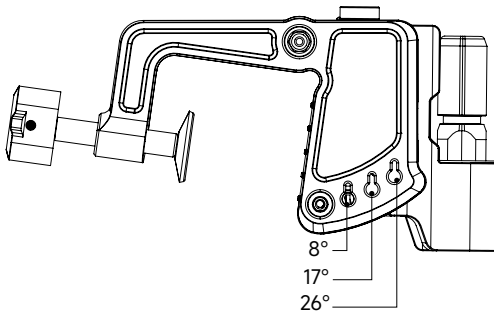

Figure 3.3

Step 1: Push the trim pin inward and rotate it 180°, with the handle facing upward.

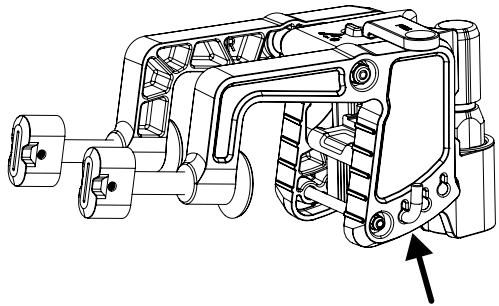

Figure 3.4

Step 2: Pull out the trim pin.

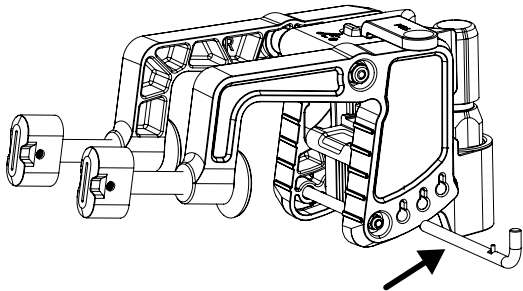

Figure 3.5

Step 3: Adjust the trim angle of the outboard motor as desired and insert the trim pin into the corresponding limit hole.

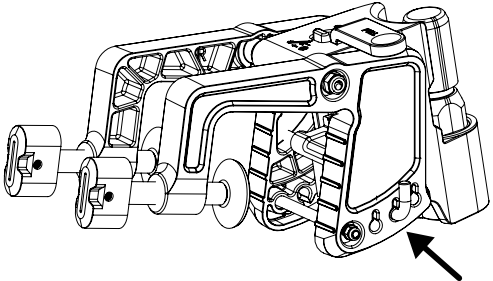

Figure 3.6

Step 4: Push the trim pin inward and tighten it, then rotate it 180°.

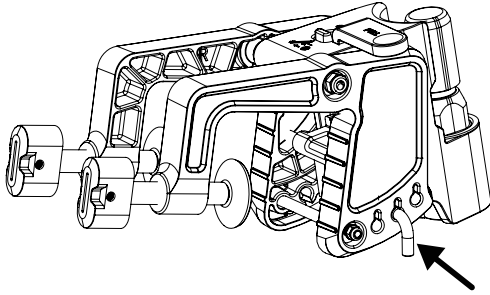

Figure 3.7

3.3 Shallow Water Mode

The ePropulsion eLite outboard motor has a shallow water mode. This allows the outboard to be partially tilted for continued operation in shallow water, such as when approaching a beach or slipway.

⚠ In shallow water mode reverse gear must not be used, as the propeller may kick up out of the water and cause injury.

Step 1: Lift the lever upward.

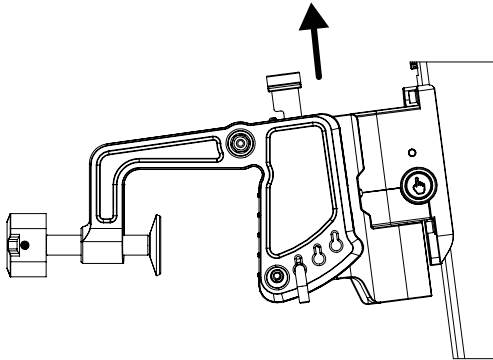

Figure 3.8

Step 2: Tilt the outboard motor to the shallow water position (you will feel a click) and release it. The motor will now stay in this position, angled 36° outwards from the transom.

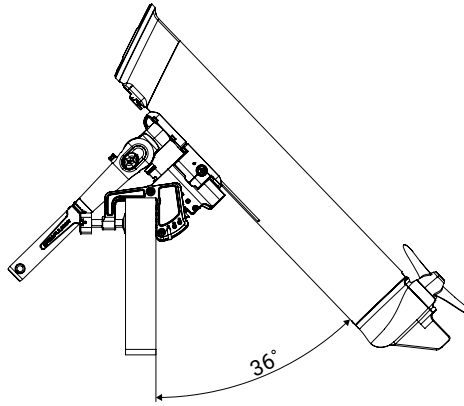

Figure 3.9

3.4 Anti-grounding Mode

The ePropulsion eLite has an Anti-grounding Mode, in which the shaft is free to kick up if it encounters an obstruction (eg rock). It's also useful when running in shallow water, such as approaching a beach.

⚠ When in anti-grounding mode reverse gear must not be used, as the propeller may kick up out of the water and cause injury.

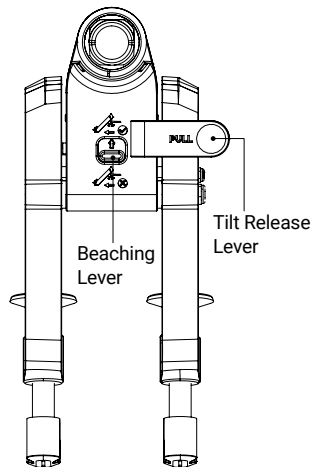

Figure 3.10

Step 1: Pull the trim lever up and hold it up with your right hand.

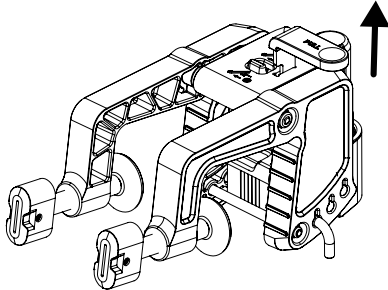

Figure 3.11

Step 2: Push the beaching lever back towards the trim lever.

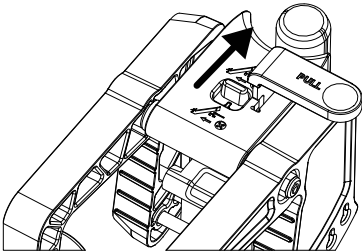

Figure 3.12

Step 3: Release the trim lever, which will now stay in the up position.

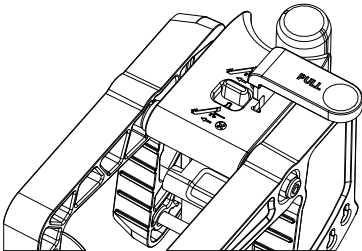

Figure 3.13

3.5 Steering Friction Adjustment/Lock

Steering Friction can be varied by adjustment to the damping screw (at bottom of clamp bracket damping shaft). If this screw is tightened further the steering can also be locked, when using a boat with its own rudder, for example.

Step 1: Adjust the heading of the outboard motor as desired.

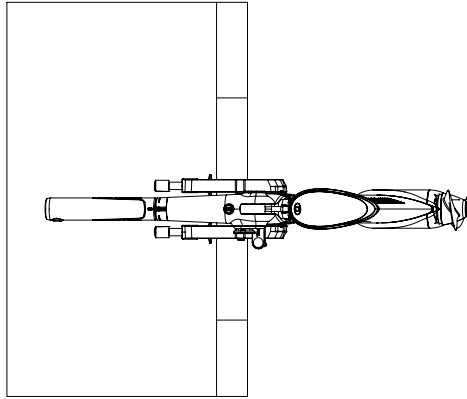

Figure 3.14

Step 2: Tighten the damping screw with a 10mm Hex wrench.

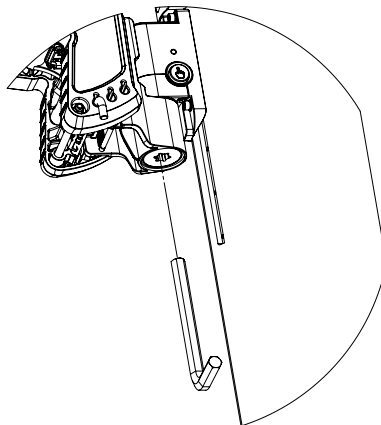



Figure 3.15

4 Installation

 Failure to secure the bracket clamp correctly may result in the outboard motor falling off, causing property damage, serious injury, or death.

4.1 Clamp Bracket Installation

 Before installing the clamp bracket, please check:

1. If clamp bracket functions properly.
2. If any components are loose.
3. If there are any cracks in the clamp bracket.

Step 1: Check the clamp bracket.

Step 2: Place the clamp bracket in the center of the transom and do up the clamp handles.

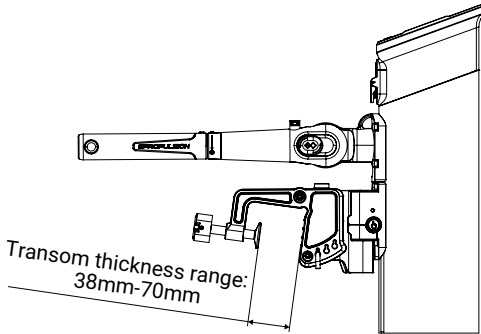

Figure 4.1

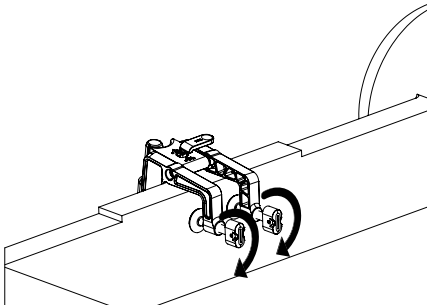

Figure 4.2

4.2 Motor Installation

- 💡 Ensure that the clamp bracket is securely installed, as a loose clamp bracket may cause the outboard motor to fall into the water or get damaged. Check the clamp handles before each use, as they may loosen due to mechanical vibrations.
- 💡 If the quick-release mount is stuck, please rinse it clean before installing the motor.
- 💡 It is recommended to use a rope or chain through the lanyard hole to connect the outboard motor and the boat, to prevent the motor from falling off the bracket, which may result in loss or submersion.

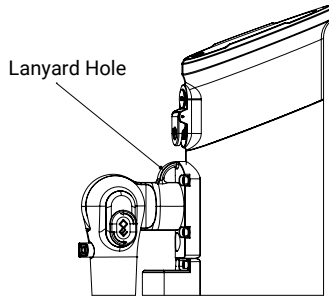

Figure 4.3

Step 1: Pull out or rotate the tiller adjustment toggle to unfold the tiller (see section 2.1).

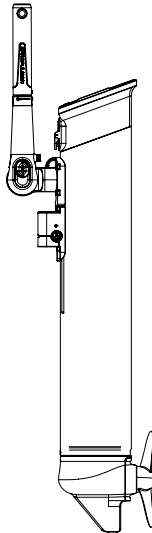

Figure 4.4

Step 2: Hold the outboard motor with both hands and align the quick-release mount with the clamp bracket damping shaft, then slowly lower the motor into place.

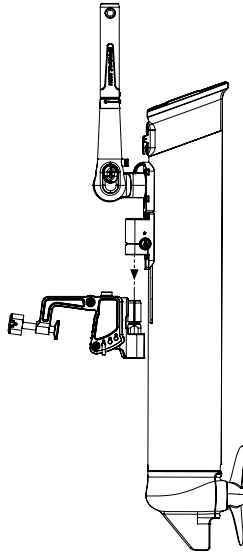

Figure 4.5

Step 3: Check the motor has seated down correctly, ie doesn't wobble, can't be pushed upwards if knocked etc.

4.3 Motor Removal

Step 1: Press the quick-release button to release.

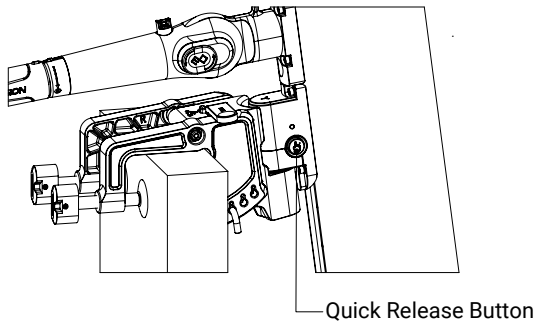

Figure 4.6

Step 2: Hold the outboard motor with both hands and slowly lift it upwards.

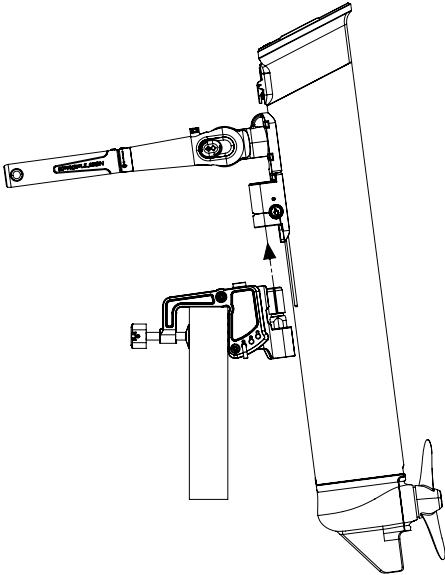

Figure 4.7

5 Operation

5.1 Checklist before start

1. Ensure the battery has sufficient charge. Press the power button once to display the remaining battery level on the display.
2. Ensure that the clamp bracket is securely fastened to the transom in the correct position.
3. Ensure the propeller is correctly installed on the outboard motor.
4. Ensure the throttle is in neutral position.
5. Ensure the throttle can move smoothly.

5.2 Starting

The ePropulsion eLite electric outboard motor has two working modes: Standard mode and Sport mode.

Standard mode: The maximum output power of the outboard motor is 500W.

Sport mode: The maximum output power of the outboard motor is 750W.

In the event of serious fault, the motor will immediately stop working and display the corresponding error code on the screen. For less serious faults it will enter a reduced power mode. Please refer to Section 6.5 for details.

5.2.1 Standard Mode

The ePropulsion eLite electric outboard motor starts in Standard mode, with a maximum output power of 500W. The maximum output power will reduce as the battery level falls or if the temperature rises above normal limits. For details, please refer to Section 6.4.

The steps to start the outboard motor are as follows:

Step 1: Attach the kill switch wristband to your wrist or life jacket.

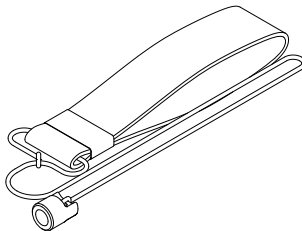

Figure 5.1

tep 2: Insert the kill switch into the kill switch hole.

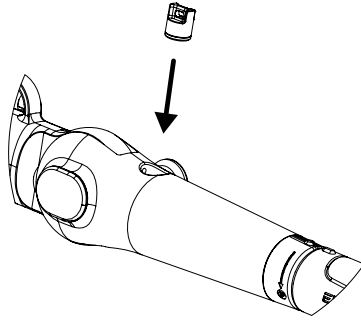

Figure 5.2

Step 3: Press and hold the power button for 2 seconds to turn on the outboard motor.



Figure 5.3

Step 4: Turn the throttle handle to move forward or backward.

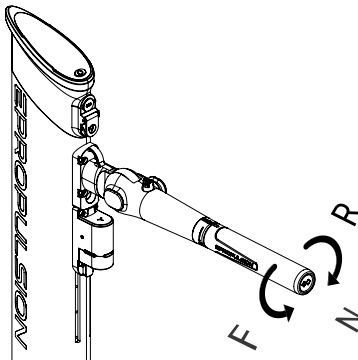

Figure 5.4

5.2.2 Sport Mode

To enter Sport mode, quickly double-press the power button while the ePropulsion eLite electric outboard motor is switched on. Double-press again to exit Sport mode. Sport mode can increase the maximum input power from 500W to 750W (when there is sufficient battery capacity), and the screen will display the letter S as shown below. The Sports Mode will automatically exit after 1 minute.



Figure 5.5

5.3 Stopping

The ePropulsion eLite electric outboard motor can be stopped in three ways.

Method 1: Turn the throttle handle to the neutral position.

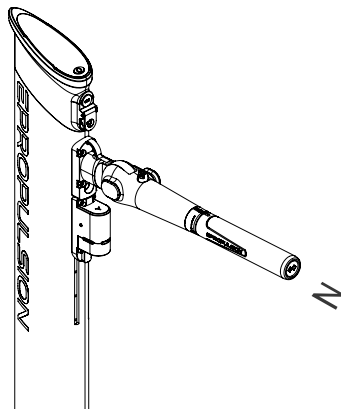

Figure 5.6

Method 2: Remove the kill switch from the kill switch hole. This will happen automatically if the driver has the kill switch lanyard attached to their wrist and falls in, for example. Always wear the kill cord!

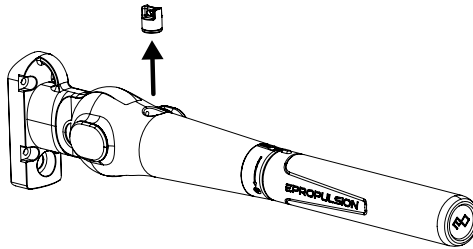

Figure 5.7

Method 3: Press and hold the power button for 2 seconds to turn off the outboard motor.

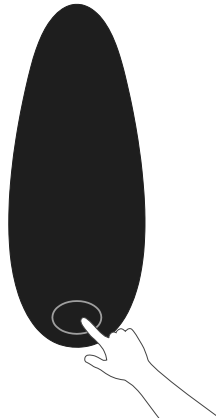

Figure 5.8

⚠ If the throttle is in the neutral position for 30 minutes without any operation, the outboard motor will automatically shut down.

5.4 Tilt Up and Release

The ePropulsion eLite Electric Outboard Motor has a trim and tilt function. If the outboard motor is going to be stopped for a period of time or the boat is going to be moored in shallow water, the outboard motor should be tilted up. This will help prevent damage to the propeller and motor housing due to collision with underwater obstacles, and also to reduce corrosion.

5.4.1 Motor Tilt

Step 1: Lift the trim lever upwards.

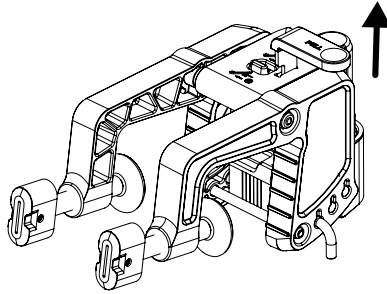

Figure 5.9

Step 2: Tilt the outboard motor to the highest point it will go, and release it. The shaft will rest in place at 75° to the transom.

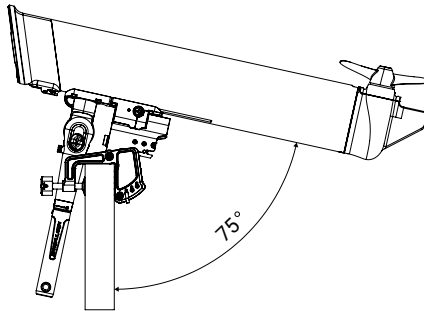

Figure 5.10

5.4.2 Motor Release

Step 1: Hold the motor main part steady with one hand and lift the trim lever upwards as high as it will go with the other hand.

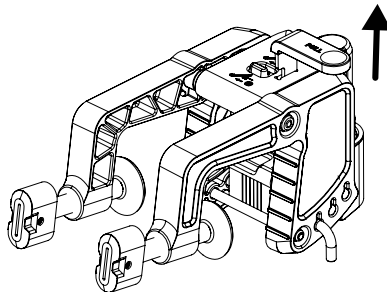

Figure 5.11

Step 2: Keeping it under control (don't let it just drop), allow the outboard to swing back down into the water. Check that it is in the desired position, ie propeller vertical when boat is loaded.

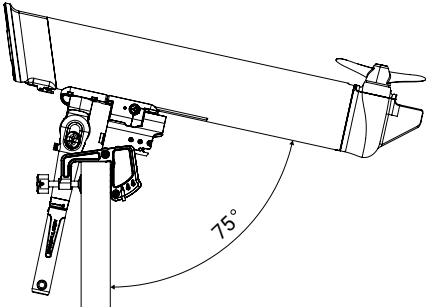

Figure 5.12

6 Interface

6.1 Display Panel

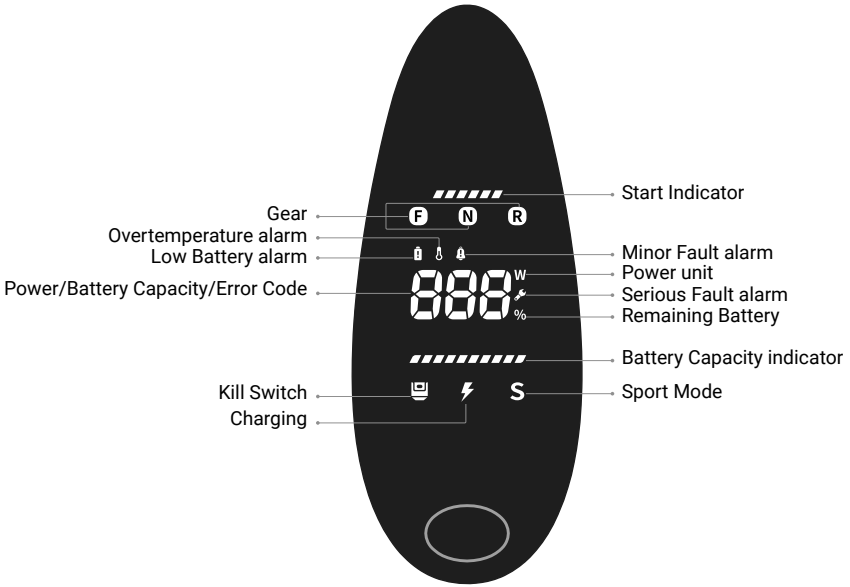

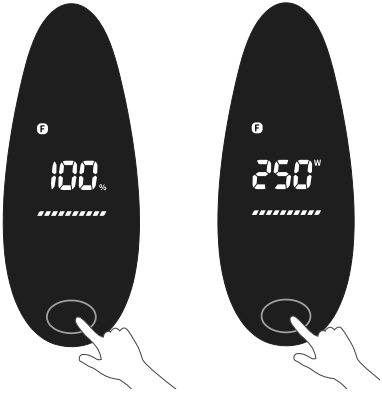

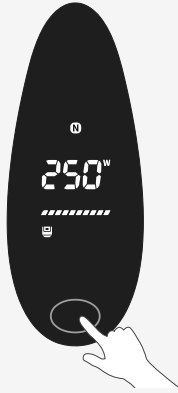

Figure 6.1

6.2 Power Button

Items	Function	Figure
Quick press power button when power is off	Check remaining battery level	<p>The diagram shows the display panel with a digital display showing '100%' and a battery capacity indicator bar below it. A hand is shown pressing the power button at the bottom of the panel.</p>

Items	Function	Figure
<p>Long press power button for 2s when power is off</p>	<p>Power on</p>	
<p>Press power button when power is on</p>	<p>Switch main numerical display between motor power input (0-750W) and battery level (%). The battery level graphic underneath continues showing in either state.</p>	
<p>Press power button twice when power is on</p>	<p>Enter Sport power mode when in Normal power mode. Return to Normal power mode when in Sport power mode.</p>	

Items	Function	Figure
<p>Long press power button for 2s when power is on</p>	<p>Shutdown</p>	
<p>Long press power button for 6s when power is on</p>	<p>Enter kill switch lost mode Kill switch lost mode is exited automatically if kill switch is in place.</p>	

6.3 Kill Switch

- ⚠ 1. Before using the kill switch, please check the kill switch wristband and cord for any tears, cuts, or wear. Always carry a spare kill switch.
- ⚠ 2. Before each use, check if the kill switch is functioning properly. Insert the kill switch into the kill switch hole, start the outboard motor and then pull out the kill switch. The outboard should stop working, the kill switch icon should flash on display, and it should make a beeping noise. If it doesn't, try a different kill switch and/or refer to dealer for advice/inspection.
- ⚠ 3. The kill switch generates a magnetic field. Keep it 50cm away from medical implants like pacemakers and magnetic cards (e.g. credit card) as well as other magnetic media.
- ⚠ 4. The magnetic field of the kill switch may interfere with some electronic instruments. Keep it away from these electronic instruments.

The ePropulsion eLite Electric Outboard Motor kill switch has interactive features with the outboard.

When operating the outboard motor, if the kill switch is detached from the kill switch hole, the outboard motor will immediately stop working and make a beeping noise. The kill switch icon and the neutral gear icon on the screen will flash.

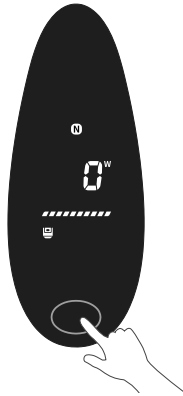

Figure 6.2

- If you still have the kill switch, replace it. Remember that the outboard motor can only be started again if the throttle is in the neutral position.
- If the original kill switch is lost, hopefully you have a spare kill switch on board and can use that. If you do not have a spare kill switch, the outboard motor cannot be started normally, but there is a kill switch lost mode. With the power on, this is entered by long-pressing the power button for 6 seconds. There will be a power-off sound when long pressing for 2 seconds, and a power-on sound when long pressing for 4 seconds. After entering the kill switch lost mode, the kill switch icon will continue to be displayed. Kill switch lost mode will be exited automatically if a kill switch is put in place.

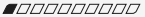

Figure 6.3

6.4 Battery Indicator

The ePropulsion eLite electric outboard motor has a battery reminder function. When the remaining battery level is at 50%, 20%, 10%, or 5%, the outboard motor will provide reminders through the screen and buzzer.

Remaining Battery Level	Battery Bar	Display	Sound Reminder	Standard Mode Maximum Power	Sport Mode Maximum Power
100%		Normally display	Yes	500W	750W
50%		Automatically switches to battery level display, and the remaining battery bar blinks 3 times. After blinking, it automatically switches back to the previous interface.	Yes	500W	Limited to 600W
20%		Automatically switches to battery level display, and the remaining battery bar blinks 3 times. After blinking, it automatically switches back to the previous interface.	Yes	500W	Limited to 600W

10%		Automatically switches to battery level display, and the remaining battery bar blinks 3 times. After blinking, it automatically switches back to the previous interface. The low battery indicator remains on.	Yes	Limited to 340W	Sport mode is not supported
5%		The remaining battery bar continues to blink, and the low battery indicator remains on.	Yes	Limited to 340W	Sport mode is not supported

6.5 Troubleshooting

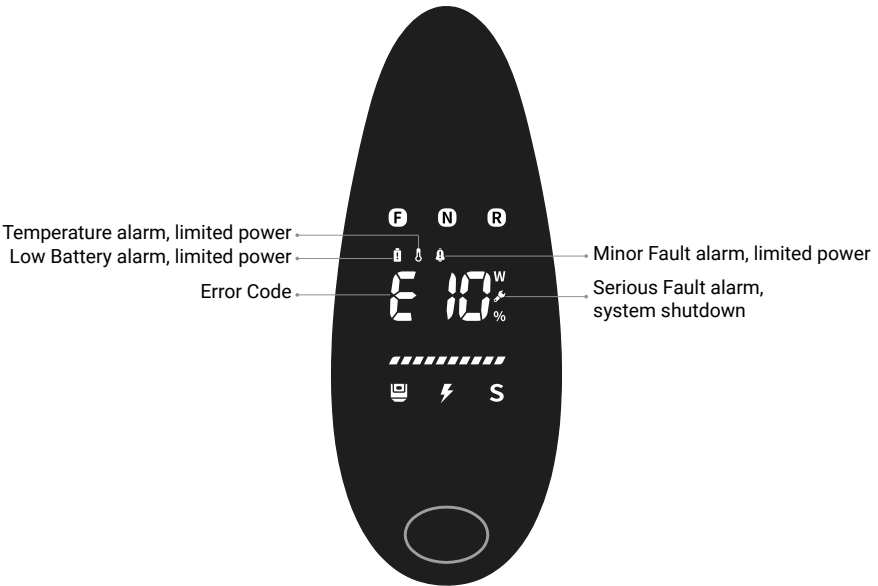





Figure 6.4

When a fault occurs, the display will show an icon or error code. Please refer to the table below to resolve the fault.

6.5.1 Fault Indicator

Icon		Function
	Low Battery	Indicates that the battery level is below 10% and the motor is in the power-limited mode. The maximum power output is limited according to the battery level, as described in Section 6.4 Battery Reminder.
	Temperature Abnormal	Indicates that the outboard motor temperature is abnormal, and it is in the power-limited mode. The maximum power output is limited to 250W or 125W.
	Minor Fault	Indicates that the outboard motor has encountered other faults, and it is in the power-limited mode. The maximum power output is limited to 250W.
	Serious Fault	Indicates that the outboard motor has encountered a serious fault and has stopped operating.

6.5.2 Error Codes

Code	Fault Cause	Solution
E14 27 40 41	Low Battery	Stop using and charge. If the problem persists after restarting, please contact an authorized ePropulsion dealer.
E25 29	Propeller Entangled	Check if the propeller is entangled. Remove the entanglement. If the problem persists, please contact an authorized ePropulsion dealer.
Other	/	Stop using, restart to check if it returns to normal. If the problem persists, please contact an authorized ePropulsion dealer.

7 Battery

7.1 AC-DC Charging

The ePropulsion eLite Electric Outboard Motor is equipped with a 378Wh lithium battery that can be charged using an AC-DC charger. The AC-DC charger can fully charge the battery in 4 hours.

The charging steps are as follows:

Step 1: Press the power button to check the remaining battery level.



Figure 7.1

Step 2: Lift up the charging cover and connect the charger as shown in the figure below.

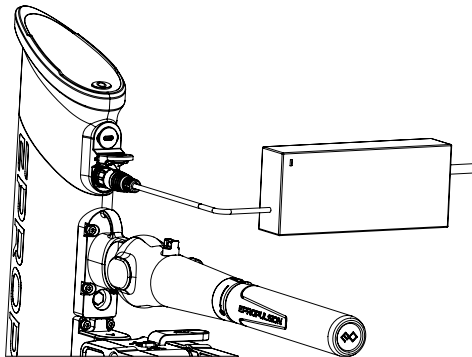



Figure 7.2

Step 3: Connect the charger plug to the socket. The charger indicator light will turn green, the outboard display will light up with a charging sound, and it will display the remaining battery level and charging icon, as shown in the figure below:



Figure 7.3

-  1. Please use the official charger. The use of non-official chargers may cause equipment damage and safety risks.
-  2. If the charger or cable is damaged, do not use it.

7.2 Charging Indicator



Figure 7.4 Battery level 100%

- 1. The battery level is displayed from left to right, with each segment representing 10% of the battery level.
- 2. When the remaining battery level is between 1% and 99%, the last segment of the battery level indicator will flash continuously during charging.
- 3. There will be a charging sound when charging starts.

8 USB Type-C Output

The ePropulsion eLite Electric Outboard Motor has a USB Type-C socket, which can be used to charge devices such as mobile phones. It turns on when the outboard is turned on, supports PD and QC3+ fast charging protocols, and can provide a maximum charging power of 22W.

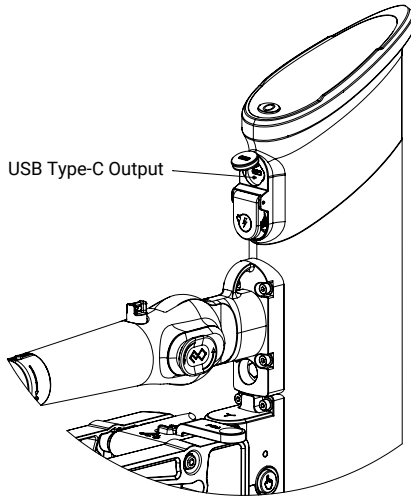



Figure 8.1

-  1. Take care not to break off the rubber plug.
-  2. When not in use, please insert the rubber plug securely to avoid corrosion of the socket.

9 Maintenance

9.1 Precautions

1. Regular maintenance keeps your outboard motor in optimal condition and extends its service life.
2. Do not start the outboard motor in shallow water near the shore. Adjust the outboard motor to the shallow water mode to avoid touching the bottom. Once the water depth is sufficient for using the outboard motor, adjust it to the appropriate gear and then start it.
3. After using the product in saltwater, promptly rinse the motor housing and all parts that come into contact with saltwater with fresh water to reduce corrosion.
4. Always perform maintenance or repairs with the outboard motor power turned off.
5. Perform maintenance or repairs under the guidance of a professional or authorized dealer.
6. If any parts of the outboard motor are damaged or need to be replaced, be sure to use ePropulsion's original parts.
7. Store the outboard motor in a cool and dry place.
8. For long-term (more than a few weeks) storage of the outboard motor, the battery level should be around 45% to 50%. The level should be checked every 3 months and topped up if necessary. Do not leave fully charged or discharged for long periods.

9.2 Propeller Inspection/Replacement

The propeller is installed on the outboard motor before leaving the factory. Before use, and periodically, the propeller and shaft should be inspected. For inspection, or if the propeller needs to be replaced, follow the diagram below.

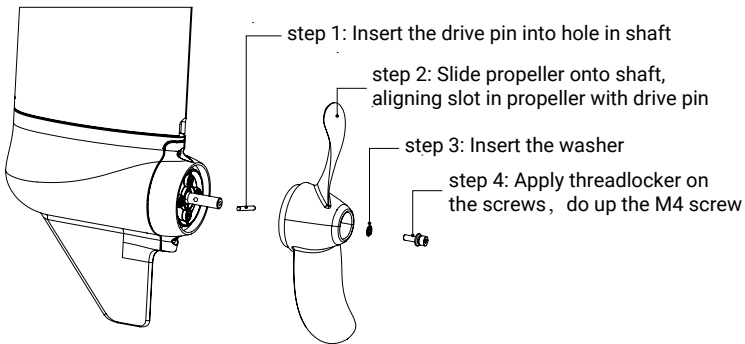



Figure 9.1

-  1. Always ensure that the outboard motor is turned off when inspecting, removing, or installing the propeller. Otherwise, serious injury may occur to the operator or nearby individuals.
-  2. The propeller blades are sharp, it is recommended to wear gloves during inspection/removal/installation.

Propeller inspection should include:

- 1. Check for wear or damage to the propeller blades.
- 2. Check the propeller shaft, drive pin and drive pin hole for wear or damage.
- 3. Check for entangled debris (such as fishing nets, fishing lines, seaweed, etc.) on the propeller and remove if necessary.

9.3 Maintenance of Electrical Contacts

Clean the charger and USB sockets with electrical contacts cleaner every two months, and immediately if there is any sign of corrosion.

10 Transportation and Storage

10.1 Portable

The ePropulsion eLite is designed so that it can be carried by the tiller when folded down in line with the shaft (-90 degree position).

- ⚠ 1. Before carrying the outboard motor, make sure to remove the kill switch from the kill switch hole.
- ⚠ 2. Before carrying the outboard motor, make sure the outboard is turned off.
- ⚠ 3. Before carrying the outboard motor, make sure the tiller is locked.

Step 1: Separate the outboard motor from the bracket clamp.

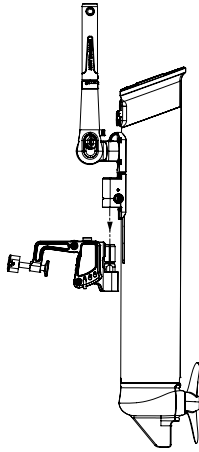

Figure 10.1

Step 2: Adjust the knob to fold the handle to -90 degrees and confirm it is locked.

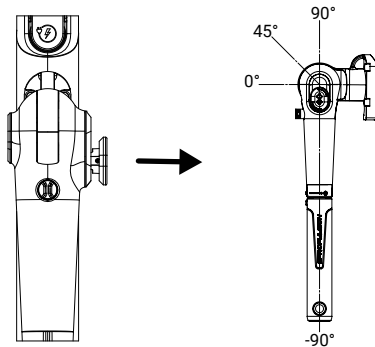

Figure 10.1

Step 3: Retract the tiller fully and confirm it is locked.

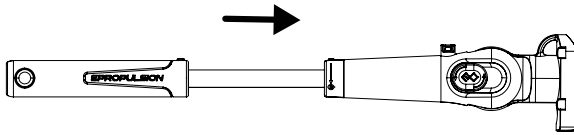

Figure 10.3

Step 4: Use the tiller as a handle to carry the outboard motor.

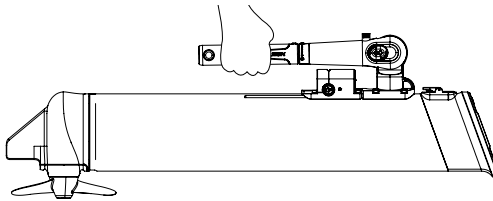



Figure 10.4

-  1. When carrying the outboard motor do not subject it to excessive movement.
-  2. If putting the motor down, make sure the outboard is placed horizontally (with the "eLite" logo facing up) on a solid surface. Do not place or balance it vertically or at an angle, as this risks it falling over and becoming damaged or causing damage.

10.2 Outboard Bag

The ePropulsion eLite electric outboard motor comes with a outboard bag for carrying and storing the outboard motor.

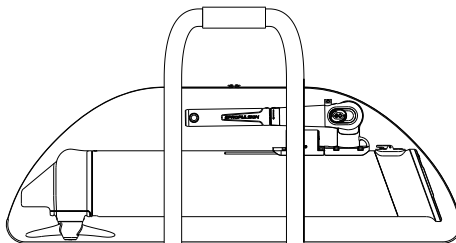

Figure 10.5

11 Emergency Situations/Actions ---

11.1 Collision

If the outboard has a significant impact with an underwater object, please:

1. Immediately shut down the motor.
2. Check the mechanical structure including propeller to see if there is damage, and the control system to see if it functions properly.
3. If you think it's still safe to operate, return to the nearest harbor or pier in low power.
4. If you don't think it's safe to operate call for assistance and/or tow.
5. Contact your authorized ePropulsion dealer for inspection and repair as necessary. Only use the motor again after it has been inspected/repared and deemed safe.

11.2 Outboard Submerged/Swamped

If the motor has not been properly stored or has been submerged in water before, the motor may be at risk of internal water ingress. In such a situation:

1. Stop it immediately and turn it off with the power button.
2. Return the outboard to an authorised ePropulsion dealer. Tell them what has happened to it so that they can inspect/repair it before further use.

12 Warranty

12.1 Terms of Warranty

Guangdong ePropulsion Technology Limited. (“ePropulsion”), China, warrants its products to be free of defects in material and workmanship under normal usage with proper installation and routine maintenance for a period of twenty-four (24) months from the date of delivery of invoice (the “Limited Warranty Period”). The Limited Warranty is provided to the first end customer of ePropulsion products ONLY. The Customer is entitled to free repair or replacement of defective or non-conforming parts. Any warranty claim must be made within six (6) months of discovery of issues as provided below.

If the Limited Warranty Period has expired, you can still enjoy maintenance services from dealers/distributors authorized by ePropulsion (the “ePropulsion Service Partners”) who will endeavour to keep costs to a minimum.

In all warranty cases, ePropulsion will only bear the repair or replacement cost for items that are covered by the Limited Warranty. Any costs not covered by the Limited Warranty – such as those related to product installation, disassembly, transportation, financing, rental, etc – shall be borne by the customer alone.

Beyond the Limited Warranty, the Customer may have statutory rights in their jurisdiction according to applicable laws. Nothing in this Limited Warranty affects such rights. The Customer may have warranty claim rights arising from the purchase contract with ePropulsion Service Partners in addition to the rights granted by this Limited Warranty.

Products used for commercial or professional purposes*, even if only temporarily, are not covered by the Limited Warranty. Instead, the statutory warranty in your jurisdiction shall apply. You are encouraged to consult with ePropulsion Service Partners for applicable warranty and advice before engaging in such use.

*** Commercial/Professional Purposes include those where the product is used with the intention of making a profit, or high frequency, or very high-reliability requirements, etc.**

To keep your warranty valid, please note the following:

- Products without the original product label will not be covered by ePropulsion’s Limited Warranty. Keep the product label intact and record the serial number from it. Never remove the label from the product;

- The Limited Warranty is not transferable and will not be reissued;
- The Limited Warranty may change from time to time. Please visit our website (<http://www.epropulsion.com>) for the latest version.

12.2 Scope of Warranty

ePropulsion may refuse a warranty claim if:

- The product is operated in contradiction to what is written in the user manual;
- Damage is caused by accident, misuse, dropping, improper care or storage, wilful abuse, physical damage, unauthorized repair;
- Water ingress is caused by external sources such as fishing nets, submersion, etc;
- Product has been modified, altered, dismantled, or had parts/accessories attached in any way not expressly permitted or recommended by ePropulsion;
- Due to failure of, or damage caused by, any 3rd party products;
- The battery has been incorrectly charged, overcharged, over-discharged, or operated in extreme temperatures;
- For items classed as Consumable (such as replacement propeller...etc.);
- Product has been purchased from unauthorized dealers or sellers;
- The problem is classed as normal wear and tear or routine servicing;
- Damage has been caused by improper packing or handling of the product during its return. The additional damage will be deemed out of warranty;
- Shipped incorrectly. The product contains lithium batteries classed as a UN9 hazardous item, and must be shipped in accordance with regulations in your jurisdiction. Non-compliance may result in warranty exclusion.

12.3 Limited Warranty Claim Procedures

The process shown below must be followed in order to make a Limited Warranty claim:

1. Contact your nearest ePropulsion Service Partner with details of the problem. They will advise if such defects are covered by the Limited Warranty or any additional rights you may have from your purchase.
2. Send the defective product to them (or the Service Partner they advise) together with Proof of 1(st)-time (first time) Purchase (e.g., receipt, invoice, etc., with information of product purchased and date of purchase), the Confirmation of Online Warranty Registration, ex-factory Serial Number, etc. Note that all labels must be kept intact. Warranty claims will only be valid only when the information above is correct, genuine, and complete.
3. Make sure the product is properly packed during delivery, the original packaging is highly

recommended.

4. The ePropulsion Service Partner will examine and diagnose the defective products to check the validity of the warranty claim.
5. If your warranty claim is accepted, the Product or its defective components/parts will be either repaired or replaced free of charge. Note that any delivery cost incurred in the process shall be borne by you.
6. If your warranty claim is rejected, a repair/replacement cost and fee with round trip delivery cost will be estimated and sent to you for confirmation. ePropulsion Service Partners will only begin the work after your written confirmation that you wish to proceed with the repair/replacement and will pay for it.

ePropulsion

(*In order to validate warranty, please fill in this form first and read the Warranty Policies.)

|| OWNER INFO. ||

Owner Name			
Address			
Phone		Email	

|| DEALER INFO. ||

Store Name			
Address			
Phone		Email	

|| PRODUCT INFO. ||

Date of Purchase (mm/dd/yyyy)	
Serial No.	



Thanks for reading this user manual.

If you have any concerns or find any problems while reading, please don't hesitate to contact us. We are delighted to offer service for you.

Guangdong ePropulsion Technology Limited

Webseite: www.epropulsion.com

E-Mail: service@epropulsion.com